



Aug. 2014

# WARREN COUNTY HISTORICAL SOCIETY

Box 256 Indianola, IA 50125 Phone-515-961-8085

(Highway 92 West, 1400 West 2nd, turn north into fair grounds)

E-mail- [cotact@warrencountyhistory.org](mailto:cotact@warrencountyhistory.org)

## Inside This Issue

- Page 2 LCF Flyer
- Page 3 Elbert J. Kuhn
- Page 5 4 Wheel Drive

## WCHS MEETINGS

**Tues. Aug. 26  
7:00 pm**

**Dick Tinder  
Warren County  
Railroads**

**Sat. Sept. 13  
Executive Board  
9:30 am**

**LCF  
10:30 am**

**September No  
General Meeting  
Due to LCF**

**2014 LCF**

**Saturday Sept. 27  
&  
Sunday Sept. 28**

**We need volunteers!  
Want to help call Dan or  
Kristi Porter 961-6149**

**LCF Garage Sale  
Please bring garage sale  
items to museum anytime  
before Saturday, Sept. 27**

**Stop at the museum to get  
quilt raffle tickets to sell  
for LCF**

## WCHS AWARDED GRANTS

Thanks again to the Warren County Philanthropic Partnership we were awarded a \$2,500 grant to paint the mural on the eastside of the museum. We have raised matching funds through donations and memorials. Dick Labertew has agreed to power wash the east wall and then paint a landscape background for the Sarchett horse mural by John Parker.



## PIES & CAKES!

We need pies and cakes for our Sunday, September 28th Pie Auction. If you could donate, contact Kathi Stanfield 961-4257 or Sally Speer at 961-3491.

## WCHS HAPPENINGS

Thanks to John Parker we have a newly painted sign on Highway 92 near Allerton's marker.

The Cooper family is going to donate two outdoor benches in memory of their father Raymond Cooper and mother Betty.

The Stanfield family, Kathi, Simon and son Brian have placed a concrete base in the garden by our entrance. Kathi is waiting for a sunny day to place on it, the original Buxton Park Sundial that had been donated to the park by Helen Grant. It had broken a number of years ago and had been donated to us.

Thanks to Mary McCormick and volunteers from the Church of Jesus Christ of Latter-Day Saints our newly acquired outdoor privy has been painted. It still needs some work but is now on display by our Mt. Hope School.

We hope that you have noticed how lovely our various flower gardens look. Susan Graeser has added plantings and is caring for our sorely neglected gardens. Susan and volunteers from Redeemer Lutheran Church tidied up the area.

Two young men from Norwalk serving as missionaries for the Church of Jesus Christ of Latter-Day Saints have been volunteering when they have free time.

Thanks to all the volunteers that helped keep the museum open during the July Warren County Fair. We had a number of visitors seeking a cool place to rest.



# LOG CABIN DAYS FESTIVAL 2014

## AGRICULTURE IN WARREN COUNTY

### SEPTEMBER 27 & 28, 2014

WARREN COUNTY FAIRGROUNDS

### Saturday

**BISCUITS & GRAVY**  
7:00-10:00AM  
WCCHS Museum Dining Room  
The Cooper Family 515-961-3058

**FARMER'S MARKET**  
8:00 AM - 4:00 PM  
Dennis Schrader 515-961-7031

**PARADE 10:00AM**  
Begins at County Admin. Bldg., 301 N. Buxton Ave. & proceeds west on Salem to the fairgrounds.  
Darlene Lawyer 515-556-7413

**ROYALTY & AWARD CEREMONY**  
11:30AM  
Museum Dining Hall

**GIANT PUMPKIN & SUNFLOWER CONTEST 12:00PM**  
Bring goods at 11; Judging at 12  
Show Pavilion Jerry Beatty 515-961-3088

**SWAN CHILI COOK-OFF**  
**JUDGING: 4:00 PM NEW!**  
Campground Shelter; Bring Chili by 3:30 or drop by Museum Thurs/Sat.  
Linda Beatty 961-3088

FEATURING THIS YEAR'S RAFFLE:  
EMBROIDERED AGRICULTURE QUILT  
By WC PIECEMAKERS!

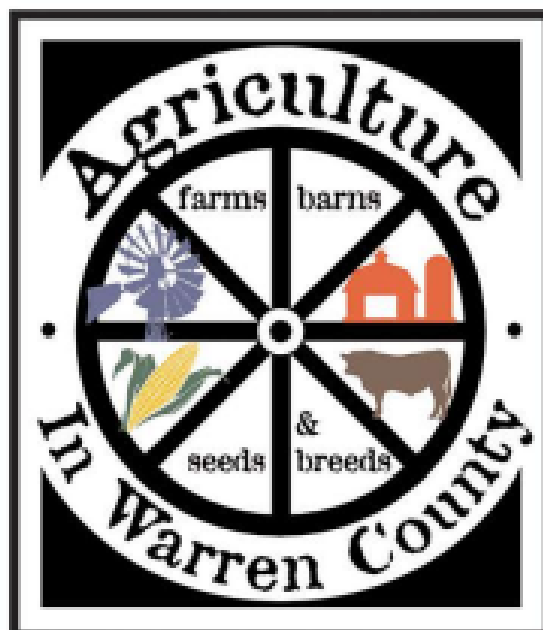

"AGRICULTURE IN WARREN COUNTY"  
COMPILATION BY JERRY BEATTY  
AVAILABLE AT THE MUSEUM

### Sunday

**CHURCH 10:00AM**  
Museum Dining Hall or  
Quaker Meeting House  
Pastor TBA

**CLASSIC CAR SHOW**  
9:00 AM - 3:00 PM  
Registration: 9 - Noon;  
Judging: Noon - 1PM; Awards: 3PM  
Lynn Downey 515-491-3357

**CHICKEN & NOODLES**  
11:30AM - 1:00PM  
WCCHS Museum Dining Room  
The Cooper Family 515-961-3058

**PIE & CAKE AUCTION**  
1:00 PM  
WCCHS Museum Dining Room  
If you'd like to donate: please call  
Kathi Stanfield 515-961-4257

**EMBROIDERED AG QUILT RAFFLE DRAWING 2:00PM**  
WCCHS Museum Dining Room  
Tickets available for purchase online,  
at museum, & locations on the square.

**KARAOKE CONTEST**  
3:00PM - 5:00PM  
Amphitheater  
Rex Young 515-961-9327

### *Saturday and Sunday*

**KID'S CORNER**  
Inflatables and Spin Art  
Mooney Doeman 515-491-8199

**ENTERTAINMENT**  
Amphitheater  
Music, Song, and Dance  
Rex Young 515-961-9327

**SCARECROW MAKING**  
Campground Shelter OR 4H Bldg.  
Dawn Nelson  
515-961-3058

**PIONEER DEMONSTRATIONS**  
4H Building - Rope Making  
Rug Hooking - Wool Spinning

**HISTORICAL MUSEUM & VILLAGE**  
**SAT. 9-5 & SUN. 10-4**  
Ruth Hall 515-961-8085  
AND WC Module Railroaders

**ANTIQUES • GARAGE SALE**  
4H Building - Linda Beatty 515-961-3088



Check out our website for updates and details.  
Find us on Facebook: [Log Cabin Days Festival 2014](#)

**QUILTS & CRAFTS**  
**SAT. 9-5 & SUN. 10-4**  
Quilts: Hort. Bldg (after parade)  
Kathi Stanfield 515-961-4257  
Crafts: Morton & Lester Bldgs.  
Dan Porter 515-961-6149



Warren County Historical Society

1400 West 2nd Avenue • Warren County Fairgrounds • Indianola, IA 50125 515-961-8085

WARRENCOUNTYHISTORY.ORG

TICKET & FLYER PRINTING: INFOMAX OFFICE SYSTEMS AND TERI COOPER



Elbert Jackson Kuhn was born February 20, 1825 in Tennessee to Peter and Elizabeth (Willet) Kuhn.

In 1846 he married Christina Cox. They had two children James M. (1847-1896) and Margaret Elizabeth (1850-1919). Margaret Elizabeth was born in Warren County.

The Kuhn family lived in Warren County in the 1850s and 60s. Elbert was a farmer and served as Warren County Sheriff from 1867-1871.

He served as a Private in the Tennessee 5th Infantry in the Mexican American War.

He was appointed 1st Lieutenant and

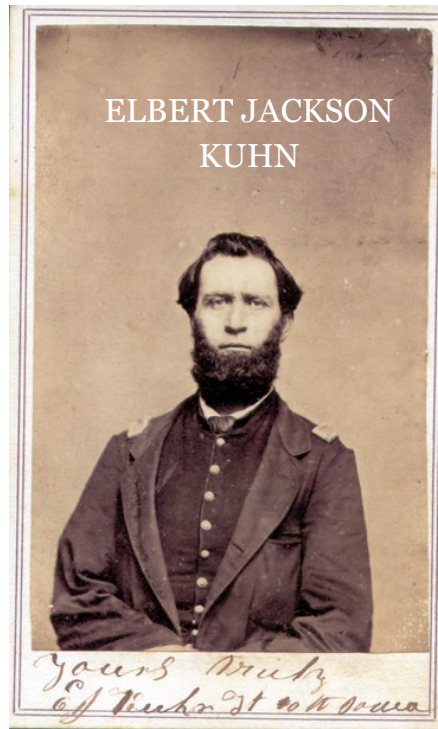

mustered September 7, 1861. January 20, 1863 he was promoted to Captain of Company G of the Iowa 10th Infantry.

Elbert was wounded in both thighs on May 16, 1863, Battle of Champion Hill, Mississippi. He resigned Nov. 6, 1864 and went back to Warren County, Iowa. He received a disability pension for his thigh wounds.

In the 1880s he moved to Kansas. His daughter Margaret Elizabeth married John S. Peck and continued to live in Warren County until her death.

Photo: Library of Congress Prints and Photographs Division Washington,

### **“Champion Hill: Decisive Battle for Vicksburg.”**

*The regiment accompanied the hazardous expedition through the tortuous windings of the Yazoo Pass, over two hundred miles from the Mississippi, and returned to Helena on the 9th of April, 1863. It now belonged to the Third Brigade of the Seventh Division of General McPherson's Seventeenth Army Corps, with which it participated in the brilliant series of battles at Port Gibson, Raymond, Jackson, Champion Hills and in that sanguinary charge upon the enemy's works at Vicksburg on the 22d of May. In all of these engagements the regiment displayed the same valor and prompt obedience to orders which it had shown in all its preceding encounters with the enemy, but its splendid achievement and heavy loss at Champion Hills on the 16th of May, 1863, is considered by many of the survivors as not only by far the most notable record the regiment made during the Vicksburg campaign but of the entire war. In that hard fought battle the division to which the Tenth Iowa belonged was commanded by the gallant General M. M. Crocker of Iowa.*

*The regiment here stood its ground in an open stand up fight, taking and returning the fire of the enemy at close range until its last round of ammunition was exhausted. On no part of the battlefield was the fighting so severe, persistent or protracted. Iowa was conspicuous in this battle, five of her regiments "the Fifth, Tenth, Seventeenth, Twenty-fourth and Twenty-eighth" being engaged, and all acquitting themselves with great credit. The Tenth lost nearly one-half of its number engaged. Of its officers, Capt. Stephen W. Poage, Lieut. James H. Terry and Lieut. Isaac H. Brown, were killed on the field, and Capt. Robert Lusby, Capt. Nathan A. Holson, Capt. Albert Head, Lieut. John W. Wright, Lieut. A. L. Swallow, Lieut. Elbert J. Kuhn, Lieut. George Gregory and Lieut. William P. Meekins, were wounded. The total loss of the regiment in this battle was 158, 34 killed and 124 wounded .*

From: Iowa in War Times, Des Moines, Iowa, W.D. Condit & Co., 1888.  
Byers, S.H.M. CHAPTER XVIII.

### **MOY SING BO**

Moy Sing Bo was for many years a laundryman in Indianola and later a waterworks employee. He was a native of China and as a youth first went to India where he found employment in a furniture store. Later he came to San Francisco, California and finally to Davenport where he was taken into the home of the Rev. and Mrs. R.L. Adams.

He was not formally adopted by Rev. Adams, a Presbyterian minister, though, the latter provided him with a home for many years.

Sing Bo was naturalized in Newton where he lived prior to rejoining the Adams family in Indianola, 40 years ago. At that time he opened a laundry here, later selling the business and accepting a job at the city water works.

He continued to live at the Adams home after the death of Mr. and Mrs. Adams about 10 years ago, acting as a servant for Miss Lida Adams, an adopted daughter of the Adams.

After the death of Miss Adams a year ago, Moy came into possession of about \$4,000 and two residential properties here. He died in 1942 at the age of 90. From Moy's Obituary in the *Indianola Record*, 1942.

**ALEXANDER HAMILTON SWAN 1831-1905**

Editor of **Indianola Herald** said except for one other man, Alex was “the best talker west of the Mississippi and his jokes all have a moral to them”.



1831 Born in Green County, PA  
 1853 Came to Iowa as a 23 year old widower (Lost wife Annie McCullough and child in PA)  
 1858 Back to PA and married Elizabeth Richey  
 1862 Came to Indianola where son William R. was born  
 1864 Daughter Louise born in Indianola  
 1865 Swan appointed to Des Moines Conference Seminary (later Simpson College)  
 1871 Swan made Secretary to the Warren County Agricultural Society (fair)  
 1869-70 Swan represented Warren County as a state representative in the 13th General Assembly  
 Swan was also a partner in several Indianola business ventures including: grocer, Warren County Bank, grain elevator, **Warren County Leader**, founded the Iowa Hereford Cattle Company (an English exporting company, a canning company, headquartered in Indianola), and helped to get a Rock Island spur from Des Moines to Indianola  
 1874 Swan moved his family to Wyoming (he continued to travel to Indianola to conduct business for 13 years)  
 1880 Swan Brothers (Alex & his brother Thomas) purchased 3, 000 acres in Indianola including Daniel H. Van Pelt’s north of Indianola (which he called North Farm, 2,000 acres) and land in White Oak Township known as South Farm. He brought to Indianola three trainloads of purebred Herefords, the first  
 1884 Sold North Farm to Swan & Bosler Land & Cattle Co for about \$80,000. Reducing his ownership percentage.  
 1885 Sold 1,000 acres for \$10,000 to Swan & Bosler  
 1887 Swan & Bosler Land & Cattle Co. sold for \$90,000 assets to John H. and George M. Bosler. The sale was 3,000 acres, 1,000 purebred Herefords, and 100 horses. Under the Boslers, John Gosling managed the North Farm. Captain Evan D. Bryant managed South Farm and E.W. Hartman, Indianola real estate broker became bookkeeper and financial manager. In 1900 Bosler sold the north farm to Jacob Piffer

Swan was a “wheeler dealer” by all accounts. His claim to fame was speculation in land, cattle and dreams. In 1872 he and his brother Tom bought land and cattle for their Wyoming ranch in Chugwater; adding 3,000 cattle in 1874 and 8,000 in 1878. At one time he owned in Wyoming an area 130 miles long and 42 miles wide (large as the state of Connecticut). He also helped build Union Stockyards at Omaha by the purchase of 2,000 acres, founded South Omaha and the town of Chugwater, Wyoming. His Chugwater ranch is on the National Register of Historic Places. In 1960 A.H. Swan was inducted into the National Cowboy Hall of Fame in Oklahoma City.

In 1887 after a harsh winter, draught and difficult economic times, he tried to refinance but was fired and sued by his own corporation for corrupt practices (Inflating herd count) and mismanagement. He filed for bankruptcy, left Wyoming and moved to Ogden, Utah. A.H. Swan made a big splash in Warren County for over two decades, rose to fame, moved west then lost most everything.

In 2014 WCHS’ LCF theme is Warren County Agriculture so we are honoring A.H. Swan, the Herefords that he introduced to Indianola and Wyoming, and his town of Chugwater, Wyoming where Chugwater Chili Mix and the 30 year Chugwater Chili Cookout Contest is held by having our own “SWAN CHILI COOKOFF” on Saturday, September 27th at 4:00 pm in the Warren County Fair Campground Shelter. Want to compete fill out the Chili Cookout form and return with your \$10.

**1st WCHS LOG CABIN FESTIVAL “SWAN” CHILI COOK-OFF**

Saturday, September 27, 2014  
 Judging Begins at 4:00 pm  
 Warren County Fair Ground’s Campground Shelter (inclement weather Museum dining-room)  
 \$10 Entry Fee

Competition types:  
 1 Vegetarian  
 2 Meat  
 3 Specialty

Judged on color, aroma, taste consistency, & aftertaste

Mail form to  
 WCHS  
 Box 256  
 Indianola, IA 50125  
 Or drop off at Museum any Thursday from 9:00 am—4:00 pm or Saturday from 9:00 am—12:00 noon

WCHS LCF “Swan” Chili Cook-off Entry Form.  
 CONTACT-  
 NAME: \_\_\_\_\_  
 ADDRESS \_\_\_\_\_  
 PHONE: \_\_\_\_\_ E-Mail \_\_\_\_\_  
 Family or Group Name (If not entering as an individual but as family or group) \_\_\_\_\_  
 CHILI CATEGORY: 1. Vegetarian \_\_\_\_\_ 2. Meat \_\_\_\_\_ 3.Specialty \_\_\_\_\_  
 \$10 Entrance Fee Enclosed (Make checks to Warren County Historical Society) \_\_\_\_\_



A. H. Swan

You provide 1 gallon or more of hot chili at 3:30 pm

You may bring prepared chili from home or make at shelter using your own equipment

Provide recipe to display

If secret, (just list basic ingredients)

Denote on scale 1-5 hotness

1 mild – 5 hottest

Questions: E-mail lindabeatty13@gmail.com

WARREN COUNTY HISTORICAL SOCIETY

TREASURERS REPORT FOR JULY, 2014

Community Bank Checking Balance  
as of 6/30/2014 \$ 23,609.81

Receipts:

General Donations

Cash 19  
Heidi Clark (for mural) 50  
Cash for mural 20  
89

Copies & Research

Cash 55  
Bryan Taylor 3  
58

Country School Books

Country School Assoc.  
of America (Jerry Beatty) 200  
Ardell Keeney 30  
Mary Belle Putz 30  
260.00

Membership

Dan Porter 15  
15

Total General Receipts \$422.00

Memorial Funds

Mary Criswell (for mural) 355  
Gerald Schimmelpfennig 600  
Karen Ohnemus Estate 4,903.59  
Total Memorial Funds \$5,858.59

Log Cabin Day Festival Receipts

Sponsors

Norwalk Ready Mix 75.00

Vendors 195.00

Raffle Ticket Sales 81.00

Total Log Cabin Day

Festival Receipts \$ 351.00

Total All Receipts \$6,631.59

Expenses:

Century Link \$ 91.72

Mid American Energy-Direct 47.80

City of Indianola 356.69

Weinman Insurance (1st quarter) 1,292.00

Dwight McCormick (Ballast) 105.84

Total General Fund Expense \$ 1,894.05

Log Cabin Day Festival Expense

EDJE Technologies 40.00

Dan Porter raffle tickets 108.08

Total LCD Festival Expenses \$ 148.08

Total All Expense \$ 2,042.13

Total CD, Money Market, &

Checking \$85,994.76

WCHS Endowment Funds as of July 31, 2014

City State Bank \$22,209.47

LPL Financial 47,824.61

Vanguard 33,733.71

Edward Jones 52,064.02

Total \$ 155,831.81

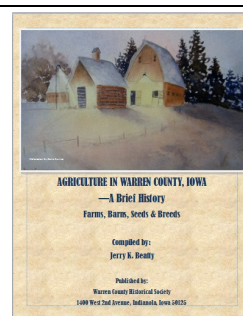

Coming soon 2014 LCF

book, **AGRICULTURE IN  
WARREN COUNTY, IOWA**

—A Brief History

**Farms, Barns, Seeds &  
Breeds**

In June in St. Joseph, MO, Jerry Beatty received a 2014 \$200 Award for Scholarship and Artistry for the book, **Rural Schools in Warren County Iowa 1847-1959**, from The Country School Association of America.





WCHS Garage Sale in 4H Building

LCF September 27 & 28

Looking for items you no longer need and would donate to our sale. Bring to museum anytime or by Friday, Sept. 26

**1915 Ford Model T Speedster Livingood 4WD - Livingood: The Trail-T Rare Rigs, A Jeep Before There Was Jeep By Jim Allen**

When the Model T debuted, there were only a handful of 4x4 manufactures in the U.S., most of which built large trucks. Only the Four-Wheel Drive Auto Company offered a line of production 4x4 touring cars, but by 1912, the limited market for such vehicles had forced them into building big 4x4 trucks. In those days, anything with four-wheel drive was nearly double the cost of a similar 4x2. The need didn't justify the cost to many people. It was much cheaper to get stuck.

Jesse L. Livingood, New Virginia, had a better idea. Seeing the need for four-wheel drive on the terrible roads of the day, he sought to develop a system at a cost more people could afford. In 1914, at the age of 20 in the corn crib, he perfected a four-wheel-drive conversion kit for the Model T. It was light, readily available, solid, and simple. In 1930 he moved to Pennsylvania.

The kit consisted of a front axle (converted from a standard Model

T rear), a revised front spring, a transfer case, a front driveshaft, and some miscellaneous pieces. The first kits used a single-speed, chain-driven transfer case with an in-out lever for the front output.

One of the unusual accessories for the Ford was a front-wheel-axle-and-differential assembly to make a four-wheel-drive Model T. For the park gardener or road repairman or the sand and gravel dealer, there were special dump truck bodies for half-ton or larger truck frames. Iron

**4 Wheel Drive Attachment for Ford Cars.**  
1923

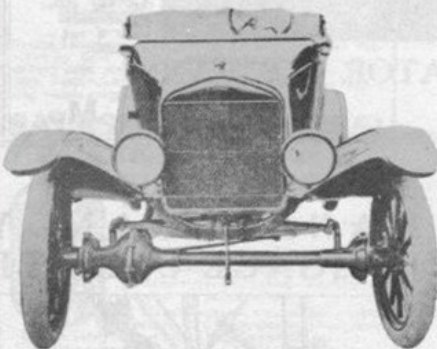

Drives and brakes on all four wheels. More power, more traction with less fuel; less tire expense and less repair bills. Will go through mud, sand and snow without the use of tire chains on any of the tires easier than a two wheel drive with chains. Think what this means. It is much safer to drive, easier to control, does not skid when you apply the brakes and can be attached to any Ford chassis in 3 to 4 hours time.

Prices on request.

J. F. LIVINGOOD New Virginia, Iowa

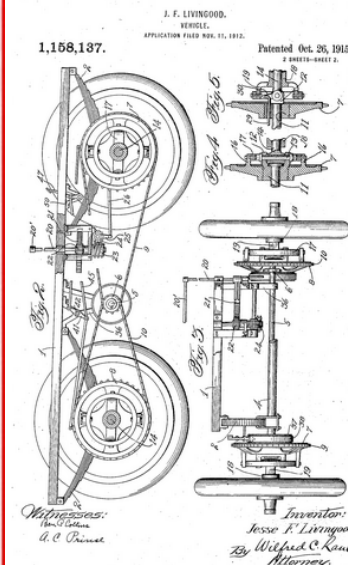

1912 Livingood U.S. Patent

**Gone but not forgotten  
Our Absent Fair Ones  
Their Bright Smiles Haunt Us**

**YOUNG LADIES WHO HAVE GONE  
OUT FROM INDIANOLA**

***The Indianola Herald*, November 2,  
1899 (Continued from May Newsletter)**

- Stella Freeman—Ft. Dodge
- Mollie Campbell Gaddis—Prescott
- Etta Gardner—Knoxville
- Myra Baker Gillespie—Evanston, Illinois
- Minnie Boatright Gillidett-Bethany, Missouri
- Ida Howard Graham—Ottawa, Kansas
- Jesse Graham—married E.R. Osbourne, manager calendar printing company, Newark, New Jersey
- Jessie Grantham—Jewell
- Etta Sinnard Graves—Des Moines
- Axie Spry Grooms—Minneapolis, Minnesota
- Bessie Guyer—married Dr. Linn, Des Moines
- Hallam—married Dr. Miller, St. Paul, Minnesota
- Mary Hallam—married Morton Moore, Carroll
- Dot Hamilton—teaches des Moines
- Anna Harding—Bussey
- Nora Noble Harvey—married George Harvey, Ute
- Ida Hamilton—nurse's training, Washington D.C.
- Alice Howard—married C.R. Kirk, druggist Chariton
- Bessie Hughes—milliner, Webster City
- Lou Humphrey—married S.L. Van Scoy Belle Plaine
- Clara Ingalls—married John Howard Carruthers, Rialto California
- Lillie Jacoby—married lawyer Frank Smith, Des Moines
- Lizzie Jay—married W.C. Davis, Chicago
- Minnie Jay—married Professor Ellenwood, Chicago
- Ella Park Johnson Des Moines
- Kate Law Johnson—Des Moines
- Jennie Jordan—nurse, Toledo, Ohio
- Nan Keeney—married George Boatright, Rock Island agent Stewart
- Laura Kendall -married W.B. Parker, editor Teton
- Peek, St. Anthony, Idaho
- Hattie Todhunter Kirkland—Denver
- Mattie Irons Lane—Stuttgart, Arkansas
- Ethel Law—married lawyer W.L. Tourney, South Bend
- Jesse Chrisinger Liston—teaches Marshalltown
- Mabel Little—teaching music, Bedford
- Ella Long—married A.L. Walters, Los Angeles, California
- Etta Lyman—married Dr. N.C. Williams Clifton Hill, Missouri
- Dora McClure—married lawyer Drew Wilder, Norton, Kansas
- Lena Coe McCorkill—Salt Lake city, Utah
- Lucy McCullough—married Oscar Israel, Chariton dry goods
- Stella McCullough—married James Malone, Adams Express CO. Chariton
- Kate Barker McCune—Boone
- Clara McGee—Boulder, Colorado